

INNOVATION IN THE PIPELINE

AXIAL  
**Isolation**  
VALVES  
AB SERIES

**GOODWIN**<sup>®</sup>  
INTERNATIONAL LTD

[www.goodwinflowcontrol.com](http://www.goodwinflowcontrol.com)



LEARN MORE

# TAKING FLOW **control** TO THE NEXT LEVEL

**GOODWIN**<sup>®</sup>  
INTERNATIONAL LTD

**INNOVATIVE DESIGN**  
**PATENTED (PENDING) FEATURES**  
3 PIECE BODY  
RACK-PINION-RACK GEAR TRAIN

The product range offered by Goodwin has now been extended to include a selection of high performance Axial Isolation Valves.

Several years of Research, Design and Testing has been carried out to bring these products to market, with international patents pending for innovative design features.

Axial Isolation Valves are used in highly demanding applications where tight shut off, high reliability and fast opening / closing are desired. Goodwin Axial Isolation Valves represent a highly effective and cost efficient alternative to current designs available to the market.

Goodwin can supply a diverse range of forged or cast valve body materials, including a wide selection of Carbon Steel, Stainless Steel, Duplex Stainless Steel, Nickel Alloy and Titanium Alloy.

Specified throughout the hydrocarbon, energy, and process industries, Axial Isolation Valves are used in a diversity of liquid, gas and multi-phase fluid applications:

- Emergency Shut Down (ESD)
- Safety Shut Off
- Over Pressure Protection (HIPPS)

[www.goodwinflowcontrol.com](http://www.goodwinflowcontrol.com)



Goodwin International is a world leader in the design, manufacture and supply of valves for the hydrocarbon, energy and process industries worldwide.

Based in the United Kingdom, the company exports to over 80 countries and offers outstanding support to its customers, including many of the world's end users, oil majors and international engineering contractors.

With 40 years of valve manufacture and international sales, Goodwin has built an enviable reputation for providing quality products at internationally competitive prices.

With valve sales in excess of 800 million USD in the past 10 years, Goodwin International is globally approved. Its high quality products are supported by an organisation that has extensive experience, knowledge and skill sets to meet today's stringent end-user specifications and their quality management system expectations.

DEMONSTRATING THE  
LEVELS OF TECHNICAL  
EXCELLENCE AND RELIABILITY  
OUR CUSTOMERS EXPECT



A NEW BREED OF  
**axial isolation**  
FOR ENHANCED SHUT OFF

Goodwin Axial Isolation Valves come equipped with innovative features that set Goodwin apart from its competition. Providing durability and reliability of performance, with the exceptional service that Goodwin is renowned for.

**OPERATIONAL BENEFITS**  
FAST OPENING/CLOSING  
TIGHT SHUT-OFF  
HIGH CAPACITY  
HIGH TURNDOWN  
RELIABILITY  
FLEXIBILITY

**FAST OPENING/CLOSING**

With operating response times of less than 2 seconds achievable, especially closure times, the Goodwin Axial Isolation Valve is particularly well suited to overpressure protection systems applications (HIPPS).

**TIGHT SHUT-OFF**

With pressure energised seals encapsulating the piston body and pressure energised seating seals in the piston head, tight shut-off to FCI 70-2 Class VI, i.e. bubble tight, is achieved. The seals are out of the line of flow when in the fully open or fully closed positions, ensuring the valve can be operated thousands of times whilst maintaining high integrity sealing.

**BI-DIRECTIONAL FLOW AND SEALING**

The Axial Isolation Valve can be flowed in either direction and, because of the pressure energised seals, bubble tight shut-off is achieved both ways.

**HIGH CAPACITY**

With an annular flow area and an unrestricted, symmetrical, streamlined flow path through the valve, Goodwin Axial Control Valves have a higher inherent flow capacity compared to conventional globe control valves and existing axial control valve designs.

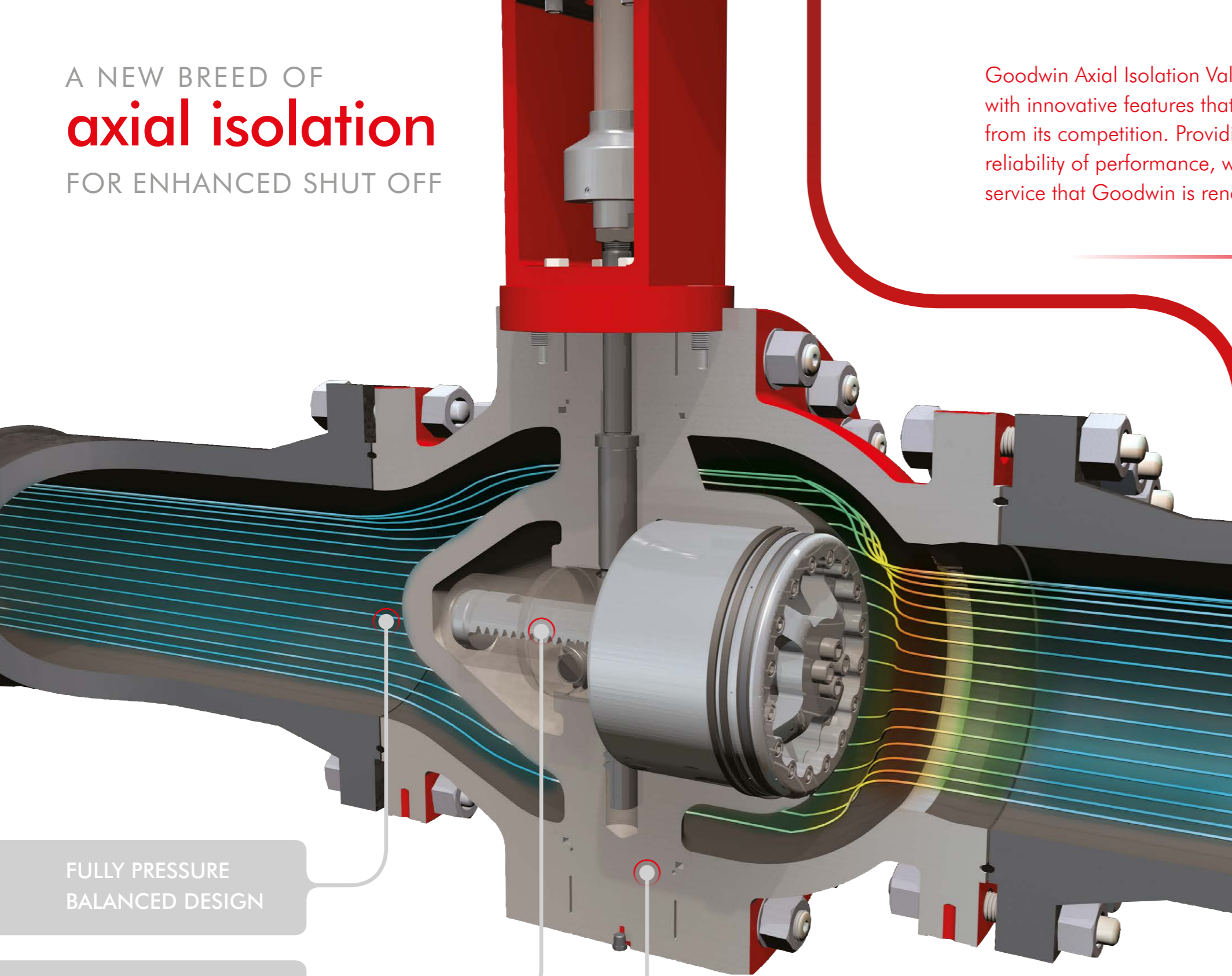

FULLY PRESSURE  
BALANCED DESIGN

RACK-PINION-RACK  
GEAR TRAIN

3 PIECE SPLIT  
BODY DESIGN



FULLY TESTED  
**LOW EMISSION**



UNPRECEDENTED  
**innovation**  
IN FLOW CONTROL

The Goodwin range of Axial Isolation Valves are equipped with innovative features that make the product more efficient, reliable and easier to maintain than any other axial valve on the market.

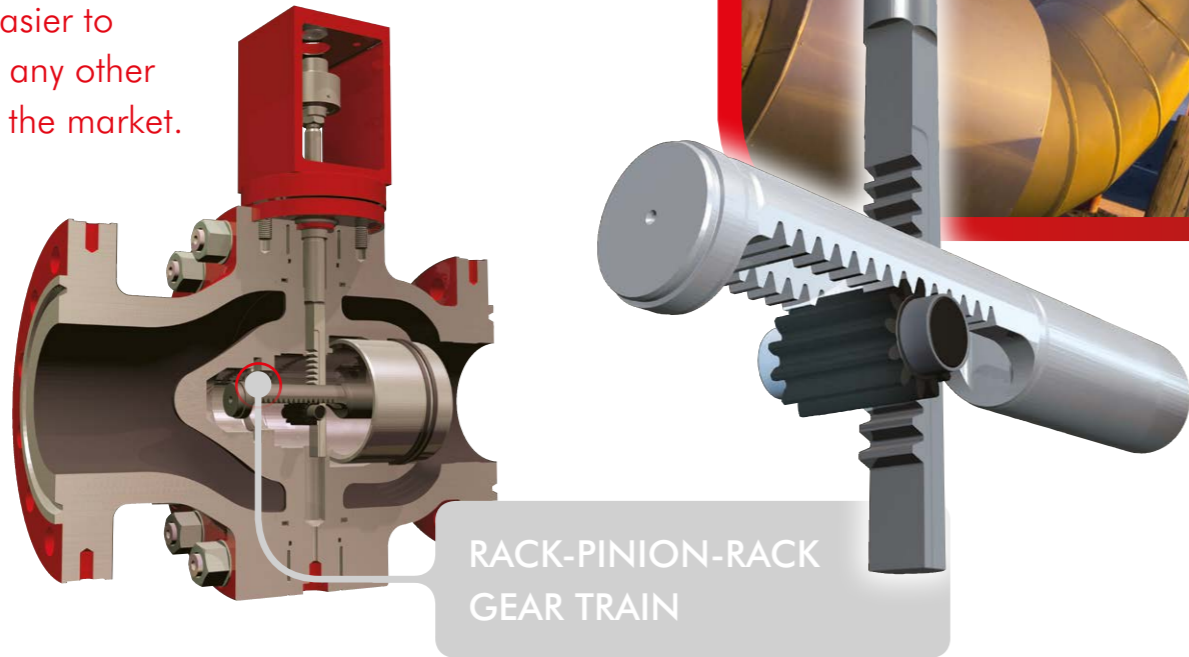

RACK-PINION-RACK  
GEAR TRAIN

The novel concept of rack-pinion-rack gear mechanism is employed in the Goodwin Axial Isolation Valve to transpose the linear motion of actuation through 90° into axial motion of the piston providing:

- High durability, rapid and precise movement
- Closure in less than 2 seconds
- Stability of operation for high turndown ratio, i.e. high rangeability
- Zero risk of gear teeth seizure with minimal or no lubrication
- Low friction and high efficiency compared to sliding gear mechanisms
- Low backlash maintained over lifetime of the product

It is almost impossible for a galling or gear train seizure failure mode to occur with the rack-pinion-rack design. A rolling gear mechanism has high efficiency and, therefore, low frictional losses, reducing the actuation forces necessary to operate the valve. The lower the forces to position the valve the less the strain and wear on the actuator promoting operational longevity. The failure mode with the rack-pinion-rack mechanism is graceful where an increase in backlash would become evident over several million cycles. The degradation is easily measured without having to dismantle the valve.



LOW MAINTENANCE  
**SEIZURE FREE DESIGN**

[www.goodwinflowcontrol.com](http://www.goodwinflowcontrol.com)

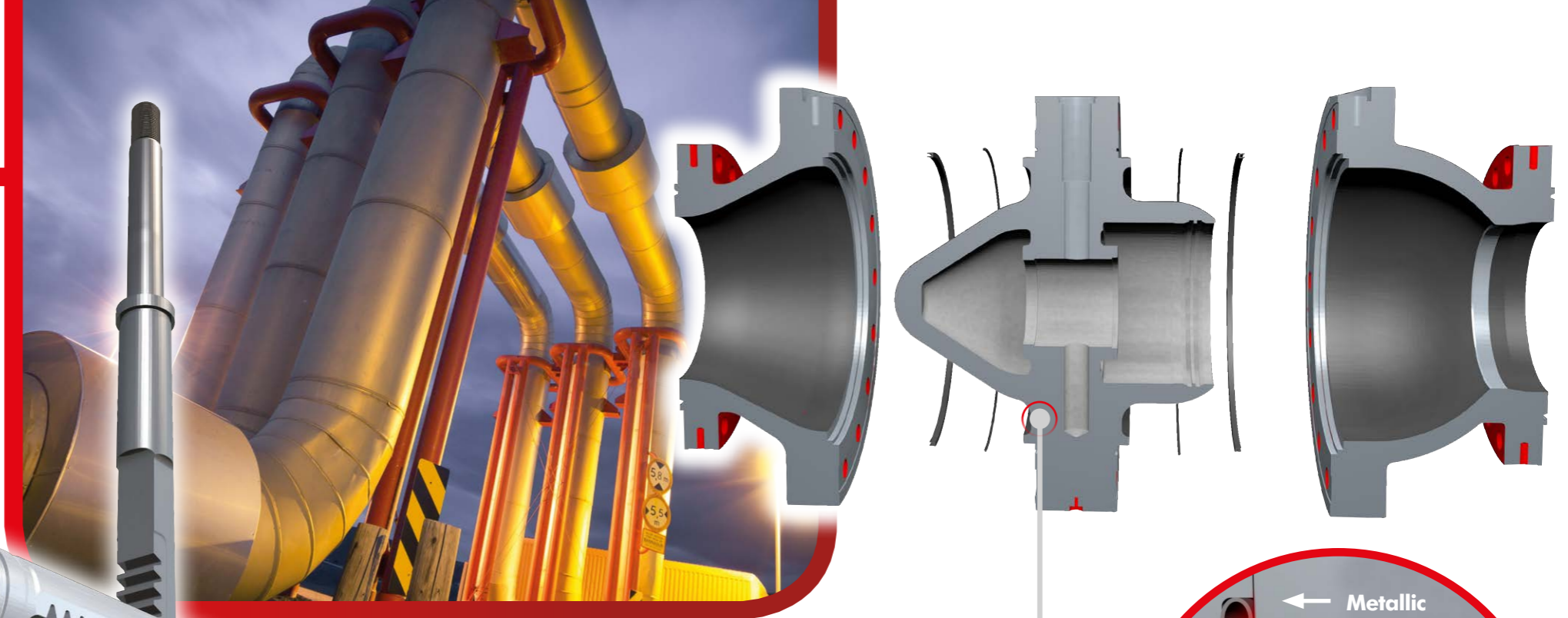

3 PIECE SPLIT  
BODY DESIGN

The Goodwin Axial Isolation Valve incorporates a novel 3 piece split body design which is widely accepted across the energy industries for other valve types providing:

- Inherent manufacturing advantages leading to reduced lead times
- Flexible design allowing the use of forgings or castings
- Inlet /outlet pipeline size transitioning feasibility within the valve for compressible fluid applications
- High capacity with larger trim sizes
- 100% Non Destructive Examination (NDE) accessibility for the pressure boundary components
- Full verification of casting quality feasibility
- Advanced sealing and precise component manufacture ensuring compliance with all international standards for fugitive emissions
- Dual redundancy sealing with primary and secondary sealing

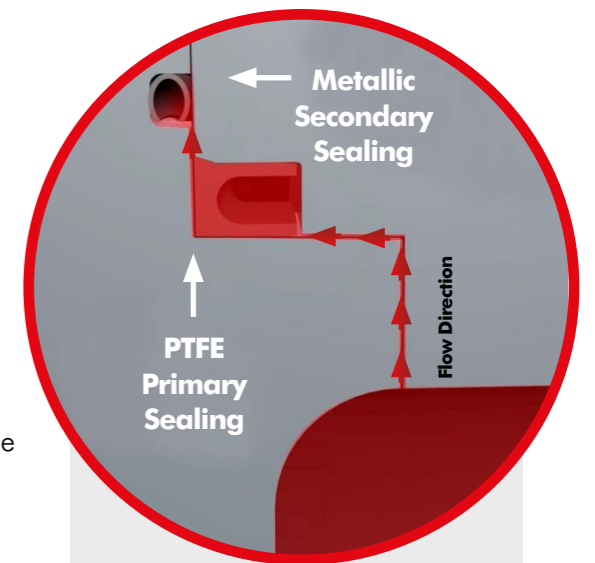

**Precision engineered bolted body joint combined with advanced primary and secondary sealing system complies easily with stringent fugitive emissions standards.**



COST & TIME  
**EFFECTIVE SOLUTIONS**

# THE ONLY CHOICE complete isolation

## VALVE SYSTEM

FULLY PRESSURE  
BALANCED DESIGN

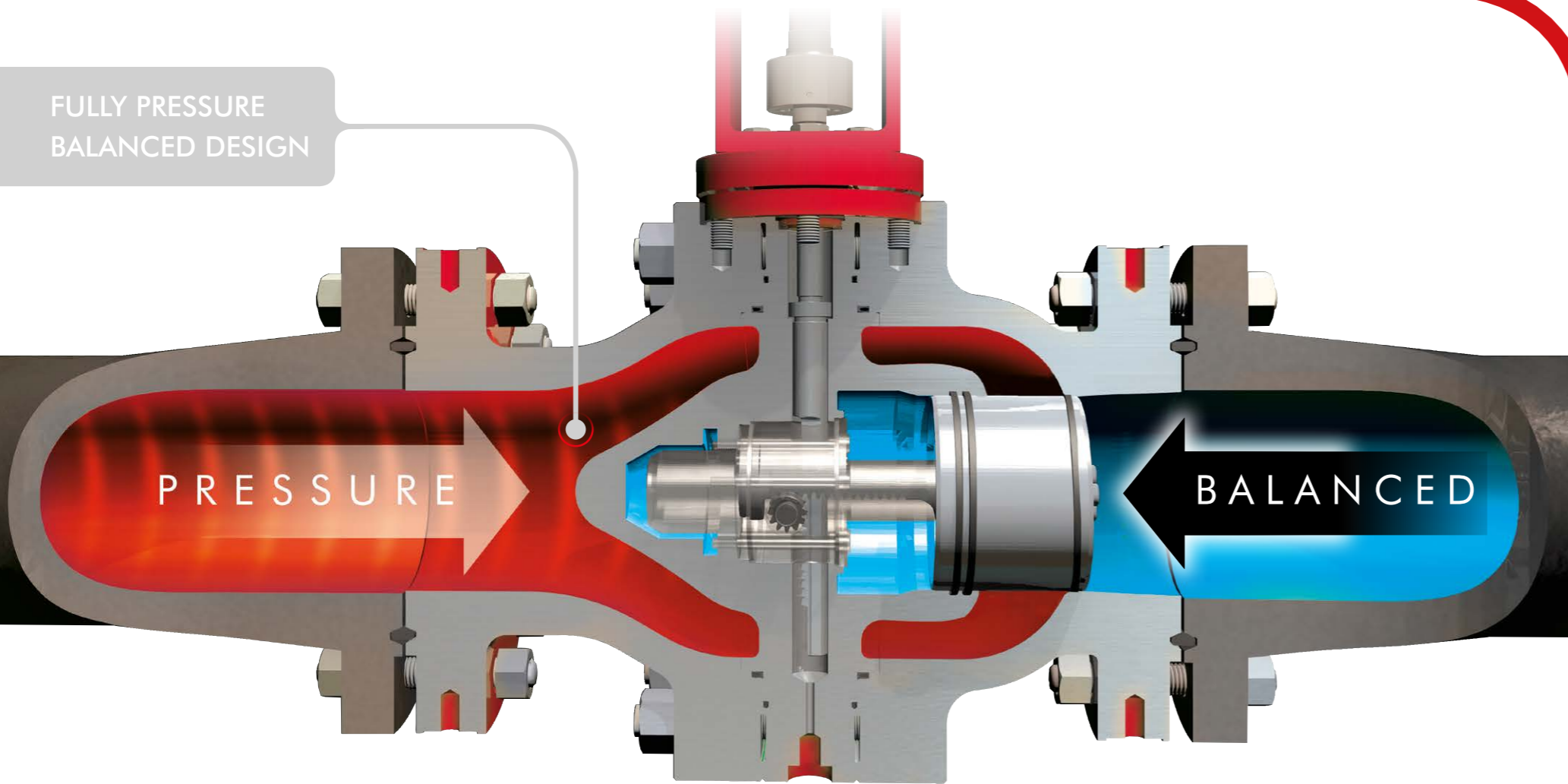

The Goodwin Axial Isolation Valve is a fully pressure balanced design, avoiding imbalance in the forces acting on the piston or the stem:

- Pressure balancing is equally effective in both forward and reverse pressure conditions
- Stable operation permits high rangeability / high turndown ratio
- The valve can be opened against full differential pressure
- Breakout forces are minimal as only the seal and mechanical frictional forces are to be overcome

- No need for a bypass or pilot valve to equalise line pressure to open the valve
- Valve closure time in less than 2 seconds can be achieved

Being fully pressure balanced, together with the low frictional forces of the rack-pinion-rack mechanism, enables the use of compact and cost effective actuation compared to other valve types.

FORWARD & REVERSE  
PRESSURE BALANCED



## ACTUATION

With the Goodwin Axial Isolation Valve being a fully pressure balanced design, actuation forces are minimised, requiring much smaller actuators than equivalent sized globe valves.

All types of linear motion actuators can be accommodated to meet control system requirements – pneumatic, electric, electro-hydraulic.

Application specific controls and instrumentation packages can be incorporated.

Actuator image is representative only. All actuator manufacturers and types are available.

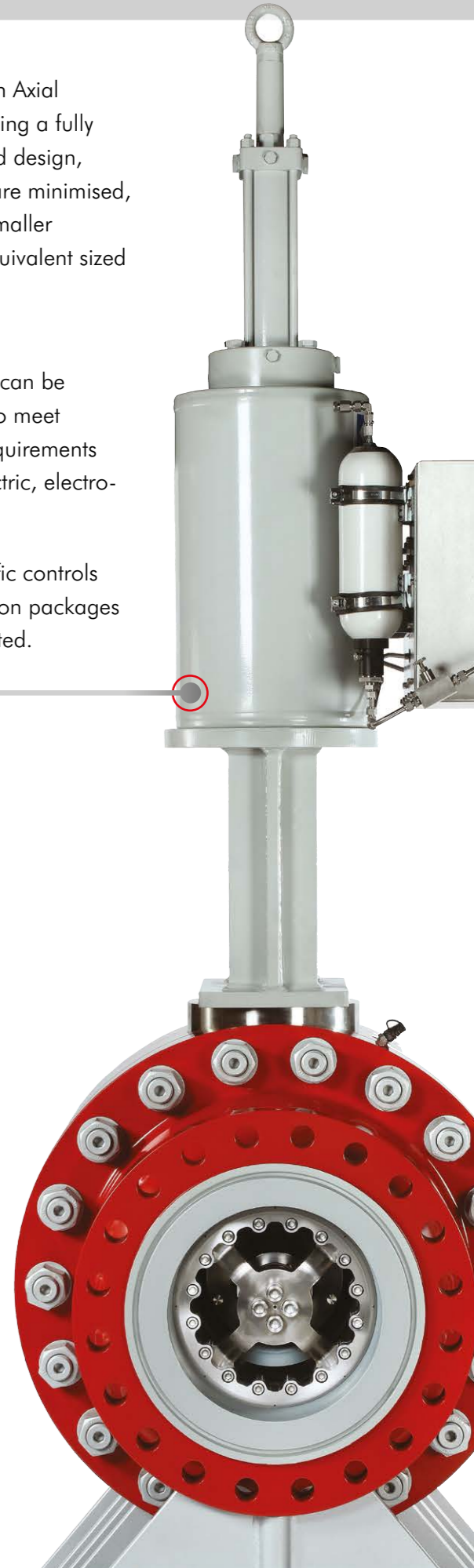

# the ultimate barrier

## Over pressure protection (HIPPS) Valve system

Mechanical HIPPS System (SIL2:1oo1)

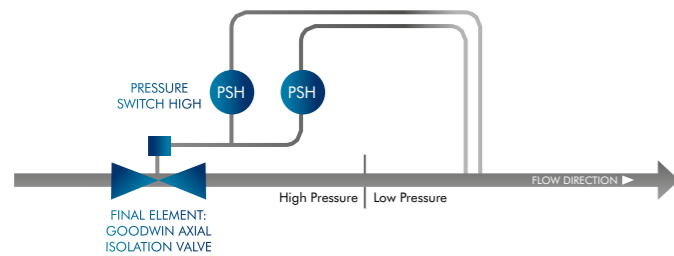

Mechanical HIPPS System (SIL3:1oo2)

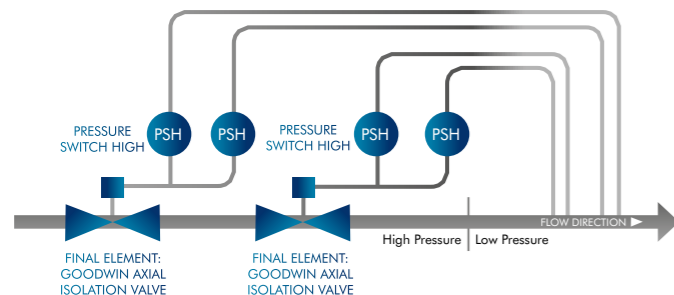

Electronic HIPPS System (SIL2:1oo1)

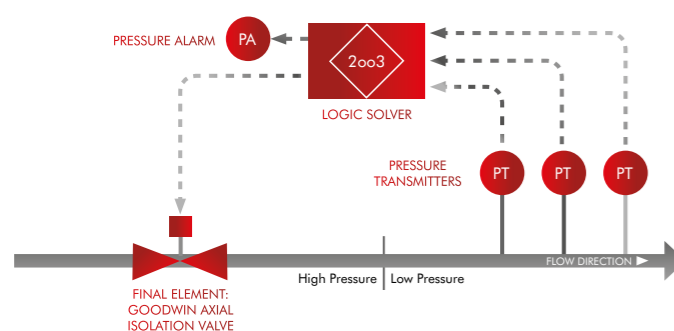

Electronic HIPPS System (SIL3:1oo2)

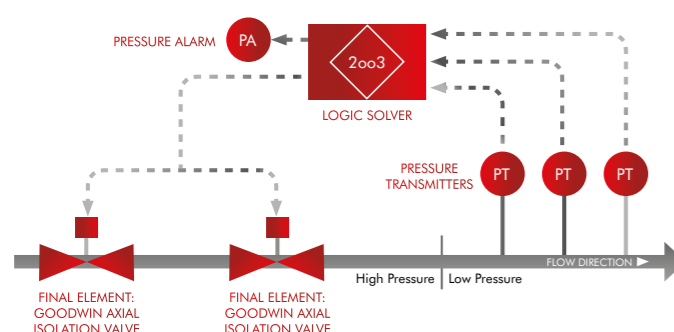

HIPPS is the acronym for High Integrity Pressure Protection System and is a type of safety instrumented system (SIS) design to prevent over-pressurisation of a pipeline or plant. It is a barrier between high pressure and low pressure systems. In the event of possible pressurisation of the low pressure system, the HIPPS will shut-off the source of the high pressure.

Designed, in accordance with IEC 61508, a High Integrity Pressure Protection System is a complete functional loop comprising three main elements:

- Initiators that detect high pressure. These can be either mechanical or electrical.
- A logic solver in the case of electronic HIPPS which processes the input from the initiators to an output to the final element.
- The final element consisting of valve and actuator to isolate the pipeline and return the system to a safe state. The valve is inherently fail safe with closure effected by venting its pneumatic or hydraulic actuator.

With its fast speed of operation, closure times of less than 2 seconds are achievable, making Axial Isolation Valves the ideal "final element" valve for HIPPS applications.

# current scope of Isolation valve manufacture

- 2"-48" valve size range
- ASME 150-2500lb, API 3000 – 15,000 pressure rating
- Carbon, Low Temperature Carbon, Stainless, Duplex, Super Duplex Steels, Low-High Alloy, Nickel Alloy and Titanium Alloy.
- Axial Valve fire tested design to API 6FA & ISO 10497 verified by Lloyds register
- Pressure testing to API 598, FCI 70-2, ASME B16.37
- Tight shut off to FCI 70-2 Class VI
- Isolation Valve in compliance with IEC 60534
- Wall thickness in accordance with ASME B16.34
- Face-to-Face dimensions generally in accordance with ASME B16.10, interchangeable with ball and globe valves. (Customer specific face-to-face available upon request)



# research & development

Extensive research and testing has been conducted by Goodwin to validate the reliability and performance of the new generation of Axial Isolation and Axial Control Valves.

- Isolation Valve sealing and mechanical performance are tested using a purpose built Hydraulic Flow Laboratory.
- Finite Element Analysis (FEA) used to verify the mechanical integrity of the design.
- Computational Fluid Dynamics (CFD) to simulate and determine flow capacity through the Axial Isolation Valve.
- Fire Testing conducted in compliance with API 6FA & ISO 10497.
- Fugitive Emissions testing conducted in compliance with International standards.
- Extensive mechanical and microstructural analysis is conducted when selecting materials to ensure compatibility and eliminate fretting and galling.
- Application specific seal performance testing.



Goodwin International has an excellent reputation as a recognised supplier to global industry.

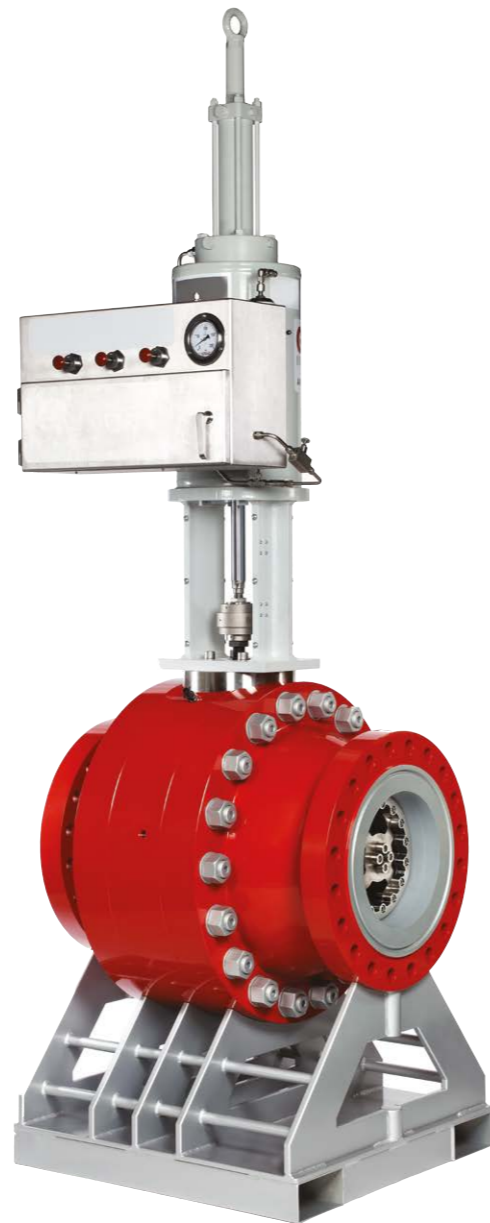

# quality

Goodwin International has an excellent reputation as an established and recognised supplier to global industry.

Quality is the bedrock of the company's ethos. Goodwin International is a highly approved manufacturer with end-user clients worldwide in a diversity of industries. Particularly so the hydrocarbon, energy and process industries. Together with today's priority considerations and objectives of Health, Safety and Environment, Goodwin provides products to all its customers backed by an integrated Quality, Health, Safety, Environment (QHSE) management system driven on the basis of continuous improvement.

- All valves are designed, manufactured, assembled and tested at its BSI EN ISO 9001 manufacturing facilities.
- Valves are certifiable in compliance with PED 2014/68/EU when required
- Extensive testing and laboratory facilities within its ultra-modern 38,000m<sup>2</sup> manufacturing plant to meet all customer valve testing requirements. Typically:

Hydrostatic Pressure Testing  
(25000 psig/1725 barg)

High Pressure Gas Testing  
(20000/1380 barg)

Low Temperature (-46°C ) and  
Cryogenic Testing (-196°C) Pressure  
Testing

- Fire tested to API 6FA & ISO 10497

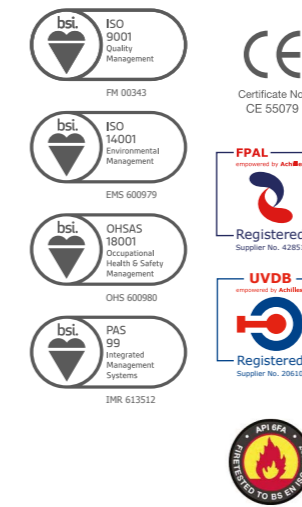

"A Goodwin Axial Isolation Valve was supplied to Technical Valve Services Ltd to assess the valve's fire safe performance. With Lloyds Register in attendance to witness and certify, a fire test was conducted in accordance with API 6FA. Engulfing the pressurised test valve in a 761°C flame environment for 30 minutes, the valve was subsequently verified for external and through seat leakage as per the standard. The valve was tested in both the preferred flow direction and the reverse direction. The same valve passed both fire tests with ease without any need to adjust or replace any of the valve components or soft seals between tests".

– Test Directors TVS

"The Goodwin Isolation valve performed well in the fire test against standard API 6FA:2011; no leakage occurred during testing in the operational direction. While it is not required by the standard, the valve was also tested against the operational direction. The easy operation of the valve after testing showed a good fire test design".

– 3rd Party Inspector Lloyds Register



# company overview

Goodwin International is globally recognised and approved for its design, manufacture and supply of valves to the world's hydrocarbon, energy and process industries.

Located in the heart of England in Stoke-on-Trent, Goodwin International is an engineering company of diverse skills, capabilities and products, and is a wholly owned subsidiary and member of the Goodwin PLC group of companies. The Group's core activities lie in engineering, refractories and investment powders and is trans-global in its activities.

The history and pedigree of Goodwin dates back to 1883. The initial company established in that year was an iron founders and engineers, R Goodwin and Sons (Engineers) Ltd. The foundry exists to this day operating under the name of Goodwin Steel Castings, and is one of the foremost nickel alloy foundries in Europe. It too is located in Stoke-on-Trent.

Publicly listed on the London Stock Exchange, Goodwin PLC is family managed. Currently the group is headed by the fifth generation of the Goodwin family with members of the sixth generation now in management positions within its operating companies.

With over 1.5 million valves in service from 40 years of supply to the global hydrocarbon, energy and process industries, Goodwin International Ltd provides a comprehensive level of customer service supported by a comprehensive representative network and its own overseas offices in Brazil, Dubai, South Korea, China and Japan.



Goodwin International



Goodwin Steel Castings

## Company Commitment...

To maintain an underlying commitment to engineering by investing in the design, manufacture and sale of technically advanced products.

The company's philosophy is to supply well designed products fit for purpose that are internationally competitive, whilst being superior to our competitors' be it by product performance or efficiency always ensuring the highest level of quality in everything we do.

Through investment in its people and markets the company aims to maintain its market position, to become a world leader in its technologies and provide exemplary customer service.

[www.goodwinflowcontrol.com](http://www.goodwinflowcontrol.com)

**Matthew Goodwin**  
Managing Director

# global offices & agents

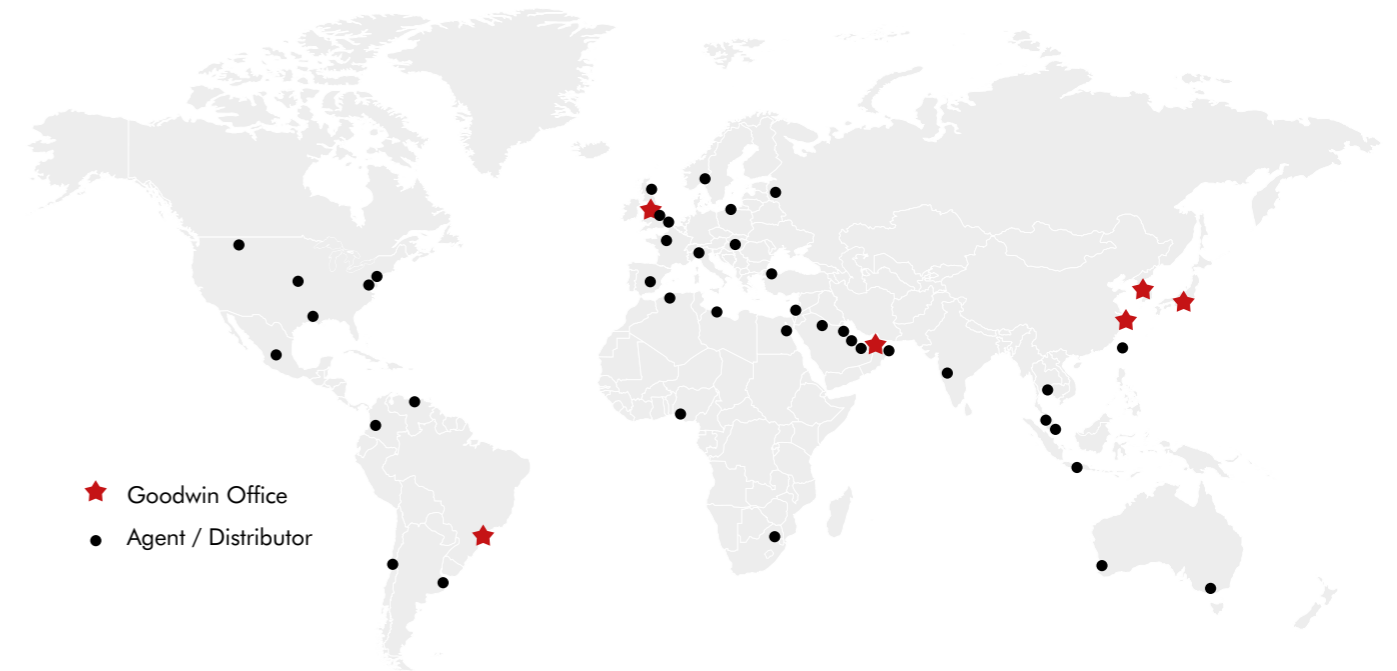

- ★ Goodwin Office
- Agent / Distributor

## Goodwin International Ltd - UK Office & Manufacturing Facility

Plantation Road  
Trentham, Stoke-on-Trent  
ST4 8HU England  
[www.goodwinflowcontrol.com](http://www.goodwinflowcontrol.com)

Tel +44 (0)1782 654000  
Fax +44 (0)1782 208060  
Email [flowcontrol@goodwingroup.com](mailto:flowcontrol@goodwingroup.com)

## Goodwin Korea Co., Ltd

13-1, Jungbong-daero,  
396 Beon-Gil, Seo-gu, Incheon,  
South Korea  
[www.goodwin.co.kr](http://www.goodwin.co.kr)

Tel +82 32 579 6313  
Fax +82 32 579 6314  
Email [goodwinkorea@goodwin.co.kr](mailto:goodwinkorea@goodwin.co.kr)

## Goodwin Shanghai Company Ltd

Suite C, F1, Building #14, Xiya Road No.11,  
Waigaoqiao Free Trade Zone, 200131,  
Shanghai, PRC  
[www.checkvalve.com.cn](http://www.checkvalve.com.cn)

Tel +86 21 50460658  
Fax +86 21 50460355  
Email [lliu@checkvalve.com.cn](mailto:lliu@checkvalve.com.cn)

## Goodwin Valve and Pump Co.,Ltd

Rua das Margaridas, 70  
Terra Preta - Mairiporã - SP  
CEP 07600-000  
Brazil  
[www.goodwinlatina.com](http://www.goodwinlatina.com)

Tel +55 11 4486 1429  
Fax +55 11 4486 3427  
Email [rarmengou@goodwinlatina.com](mailto:rarmengou@goodwinlatina.com)

## Goodwin International Ltd Japan Liaison Office

Tel +81 904177391  
Email [kfuruzono@goodwingroup.com](mailto:kfuruzono@goodwingroup.com)

## Goodwin International Ltd Middle East Liaison Office

Tel +971 552559724  
Email [akamesh@goodwingroup.com](mailto:akamesh@goodwingroup.com)





**AXIAL ISOLATION VALVE**



**AXIAL HIPPS VALVE**



**AXIAL CONTROL VALVE**



**AXIAL CHOKE VALVE**



**DUAL PLATE CHECK VALVE**



**AXIAL NON-SLAM CHECK VALVE**